



PanaFlow HT

Panametrics ultrasonic SIL flow meter for liquids

Applications

PanaFlow HT is a SIL-rated flow meter used for flow measurement of liquids in either nominal or extremely high or low process temperatures. It is the first ultrasonic flow meter to receive SIL (Safety Integrity Level) certification. As a safety flow meter, or coker flow meter, the PanaFlow HT SIL flow meter is designed for use in safety-critical applications where reliability ensures reduction in risk to personnel, to plant assets, to the environment and to corporate reputation. It also brings advantages to any non-safety critical application where reliable ultrasonic flow measurement is required.

- Coker crude distillation
- Vacuum distillation
- Crackers
- Hydrotreaters
- Visbreakers
- Crude oil
- Liquefied natural gas (LNG)

Features and benefits

- No drifting flow measurement
- No periodic calibration required
- No maintenance
- No restriction in the pipe
- Reliable measurement by design— (IEC61508 certification)
- Flow measurement in extremely high-process temperature (600°C/1112°F) applications
- Flow measurement in extremely low-process temperature (-200°C/-328°F) applications
- Bi-directional measurement

PanaFlow gives you confidence in your flow measurement

PanaFlow HT is a wetted ultrasonic flow meter that is SIL certified (IEC61508) by design to give you confidence in your flow measurement and to provide reliable flow meter operation for both safety and process control systems. It is the first SIL-rated ultrasonic flow meter on the market.

In addition to the peace of mind that SIL certification brings, PanaFlow HT also has all the advantages of ultrasonic flow measurement over other traditional technologies—no measurement drifting, no periodic calibration requirement, no restriction in the pipe, minimal pressure drop, no maintenance, and no moving parts.

Fast and easy installation

Wetted systems typically provide higher accuracy than clamp-on systems, but installation can be complicated and difficult. If these systems are not installed with precision and close attention to detail, reliability and accuracy may not meet the product specifications. With the PanaFlow HT system, we do the assembly work at the factory. The necessary components are already installed, so all you need to do is bolt the end flanges into place.

Transit-time flow measurement

In this measurement method, two transducers serve as both ultrasonic signal generators and receivers. They are in acoustic communication with each other, meaning that the second transducer can receive ultrasonic signals transmitted by the first transducer and vice versa.

In operation, each transducer functions as a transmitter, generating a certain number of acoustic pulses, and then as a receiver for an identical number of pulses. The time interval between transmission and reception of the ultrasonic signals is measured in both directions. When the liquid in the pipe is not flowing, the transit-time downstream equals the transit-time upstream. When the liquid is flowing, the transit-time downstream is less than the transit-time upstream.

The difference between the downstream and upstream transit times is proportional to the velocity of the flowing liquid, and its sign indicates the direction of flow.

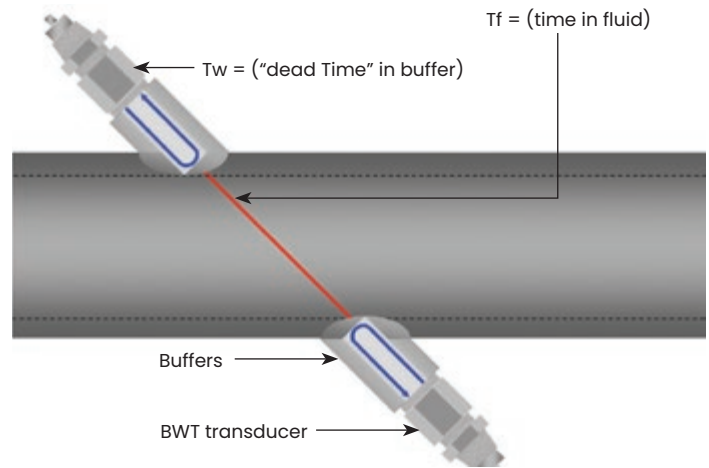

Active temperature compensation

Ultrasonic flow meters use transit time to determine the liquid or gas flow in a pipeline. Measured transit time consists not only of the time the ultrasonic signal spends in a fluid, but also of a portion of "dead time," which is the time that the electrical signal is converted into an acoustical signal and the time the acoustic signal travels inside the buffer. To allow for the utmost accuracy, PanaFlow HT uses pulse echo technique to actively measure the dead time. By sending a pulse and measuring its reflection, the dead time is measured in real time rather than using a preset value. As a result of this GE invention, PanaFlow HT maintains its accuracy as process temperature conditions dynamically change.

What is the PanaFlow HT system?

The PanaFlow HT system consists of the new XMT1000 electronics, BWT transducer system, and meter body. The Panametrics XMT1000 is our latest transmitter and it combines state-of-the-art flow measurement capability with rigorous IEC61508 software and hardware testing.

The Bundle Waveguide Transducer (BWT) system is field-proven to give accurate, drift-free, obstruction-less flow measurement in the most difficult liquid applications, while allowing access to the transducers at any time. The system consists of buffer assemblies and transducers.

The buffer assemblies use waveguide bundles to efficiently concentrate a greater amount of the transducer ultrasonic signal into the process. At the same time, the bundles act as buffers to protect the transducers from extreme temperatures to ensure their unlimited life. This innovative design greatly expands the range of possible applications. The ultrasonic signal transmitted through the buffer assemblies is powerful enough to penetrate all liquids, including high-viscosity, high-molecular weight liquids and liquids. The meter body comes in various configurations for pipe sizes up to 16 in (400 mm) standard and up to 72 in (1800 mm) upon request. Also, the meter body is available in several materials and finishes.

Safety terminology

Overall safety is defined as the freedom from unacceptable risk of physical injury or of damage to the health of people, either directly, or indirectly as a result of damage to property or to the environment.

Functional safety is the dependency on a system or piece of equipment under control to operate correctly and it is just one part of overall safety.

The goal of functional safety is to design, build, operate, and maintain systems in such a way as to prevent dangerous failures, or at the very least, to control them when they arise.

A risk-based approach must be used to determine the required performance of safety systems.



IEC61508 standards

The common use of electronic control systems and their impact on equipment safety led to the development of the IEC 61508 family of standards, which focuses on the functional safety of electrical/electronic/programmable safety-related systems.

These international standards, introduced in 1998, led to the development of further standards (IEC61511 for Process Industry, as an example).

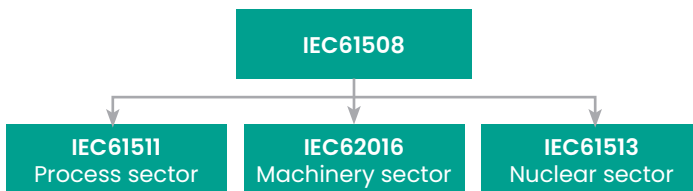

Safety Instrumented System (SIS)

A Safety Instrumented System (or Safety Related System per IEC61508) is used to implement one or more Safety Instrumented Functions (SIFs).

SIF refers to a specific single set of actions and the corresponding equipment needed to identify a single hazard and act to return a system to a safe state. In a typical SIF, sensors identify a hazard, a logic solver determines the appropriate action, and final elements perform the actions.

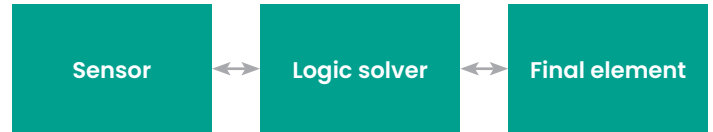

SIS automatically takes an industrial process to a safe state when specified conditions are violated. It permits a process to move forward in a safe manner when specified conditions allow.

How does PanaFlow HT fit with functional safety?

PanaFlow HT is a SIL2 ultrasonic flow meter (sensor) with the capability of a SIL3 system achievable in a redundant design configuration.

It is IEC61508 certified through a complete design validation from a third party organization. By achieving a third party certification, we have proven the required design rigor through the product safety lifecycle and functional safety management. This rigor makes PanaFlow HT the optimal ultrasonic flow meter for your safety or process control system.



Overall operation and performance

Fluid types

Liquids: acoustically conductive fluids, including most clean liquids, and many liquids with small amounts of entrained solids or gas bubbles

Flow measurement

Patented Correlation Transit-Time™ mode

Meter sizes

3 in to 16 in (80 mm to 600 mm) standard
Optional: sizes up to 72 in (1800 mm) are available upon request

Accuracy

±0.5% of reading

3 in to 4 in (80 mm to 100 mm) meter sizes,
range: 7 to 40 ft/s (2.13 to 12.19 m/s)

6 in to 36 in (150 mm to 900 mm) meter sizes, range: 3 to 40 ft/s (0.91 to 12.19 m/s)

±0.9% of reading

3 in to 4 in (80 mm to 100 mm) meter sizes,
range: 3 to 7 ft/s (0.91 to 2.13 m/s)

Final installation assumes a fully developed flow profile (typically 10 diameters upstream and 5 diameters downstream of straight pipe run) and single phase fluids. Applications with piping arrangements that induce swirl (e.g., two out-of-plane elbows) may require additional straight run or flow conditioning.

Larger meter sizes are available upon request.

Repeatability

±0.25% of reading

3 in to 4 in (80 mm to 100 mm) meter sizes,
range: 7 to 40 ft/s (2.13 to 12.19 m/s)

6 in to 36 in (150 mm to 900 mm) meter sizes, range: 3 to 40 ft/s (0.91 to 12.19 m/s)

±0.5% of reading

3 in to 4 in (80 mm to 100 mm) meter sizes,
range: 3 to 7 ft/s (0.91 to 2.13 m/s)

Range (bidirectional)

0.1 to 40 ft/s (0.03 to 12.19 m/s)

Rangeability (overall)

400:1

SIL certification

IEC61508 certified

SIL2 certification with single design system

SIL3 certification with redundant design system

Configurations

1PIR – one path, one electronics

2PIR – two path, one electronics

1P2R – one path, two redundant electronics

1P3R – one path, three redundant electronics

1P4R – one path, four redundant electronics

2P4R – two path, four redundant electronics

Other designs available upon request

Meter body/transducer

Meter body materials

Carbon steel (ASTM A106 Gr. B – ASTM A105)

Stainless steel (ASTM A312 Gr 316/316L – A182 Gr. 316/316L)

9Cr-1Mo (ASTM A335 Gr. P9 – ASTM A182 Gr. F9)

Optional: other materials available upon request

Transducer system and material

Bundle Waveguide Technology™ (BWT) System transducer and holder

316L stainless steel

Optional: Other alternative buffer materials are available upon request

Transducer temperature ranges

Normal temperatures: -310°F to 600°F (-190°C to 315°C)

Liquids, high temperatures: -310°F to 1112°F (-190°C to 600°C)

Pressure range

Up to ANSI 600 class pressure rating based on material of construction

Optional: Up to ANSI 2500 class maximum allowable flange operating pressure at temperature in either ANSI or DIN designs

Transducer classifications

Explosion-proof Class I, Division 1, Groups B, C, & D ATEX:

Flameproof II 2 G Ex d IIC T6

IECEx: Flameproof Ex d IIC T6



Bundle Waveguide Technology™ system, FTPA normal and high temperature buffers

Electronics

Enclosures

Powder coated aluminum (copper free) or stainless steel (SS316), IP66/IP67

Electronics certifications

Explosion-proof Class I, Division 1, Groups B, C, and D

ATEX - Flameproof II 2 G Ex d IIC T6 Gb

IECEx - Flameproof Ex d IIC T6 Gb

ROHS compliance

(Category 9 exemption)

CE

WEEE compliance

Electronics mounting

Remote mounting

Channels

One or two (two channels for two-path averaging)
three path measurement available upon request

Display languages

English

Keypad

Built-in magnetic, six-button keypad, for full functionality operation

Inputs/outputs

Standard

- One 4 to 20 mA isolated output, 600 Ohm maximum load, NAMUR NE43
- One additional output, may be configured as either a pulse or frequency output

Optional input/output

- One 4 to 20 mA (SIL) isolated output, 600 Ohm maximum load, NAMUR NE43 (required for SIL installation)
- Two additional 4 to 20 mA isolated outputs, 600 Ohm maximum load, NAMUR NE43
- One or two 4 to 20 mA isolated inputs, 24-VDC loop power, NAMUR NE43
- One or two isolated, three-wire RTD (temperature) inputs, -148°F to 662°F (-100°C to 350°C), 100 Ohm or 1000 Ohm platinum
- One or two isolated, four-wire RTD (temperature) inputs, -148°F to 662°F (-100°C to 350°C), 100 Ohm or 1000 Ohm platinum

Digital interfaces

- Standard: RS485/Modbus®
- Optional: HART® 7.0 protocol, with four dynamic variables, includes one additional 4 to 20 mA analog output NAMUR NE43
- Optional: Foundation Fieldbus® FISCO, LAS capable NAMUR NE107 with five AI blocks and a PID block

Power supplies

Standard: 100-240 VAC (50/60 Hz)

Optional: 12-28 VDC

Wiring connection

¾" NPT

M20

Operating temperature

-40°F to 149°F (-40°C to 65°C)*

*Maximum ambient temperature of 140°F (60°C) with foundation fieldbus option selected.

Storage temperature

-40°F to 158°F (-40°C to 70°C)

Data logging

XMT1000 meter logging Vitality software logging



Panametrics XMT1000 transmitter

Ordering information

<p>PFHT1P1R PFHT2P1R PFHT1P2R PFHT1P3R PFHT1P4R PFHT2P4R</p>	<p>03 04 06 08 10 12 14 16 S</p>	<p>15 30 60 S</p>	<p>CS SS 9C S</p>	<p>A B C S</p>	<p>A P</p>	<p>1 2 3 4</p>	<p>R</p>	<p>HT05 NT05 HT02 NT02</p>	<p>UX UXSS</p>	<p>1 2 3</p>	<p>03A 04A 06A 08A 10A 12A 14A 16A 03B 04B 06B 08B 10B 12B 14B 16B S</p>	<p>A B C D E F G H I J K S</p>	<p>0 S</p>														
<p>PFHT1P1R</p>	<p>-</p>	<p>03</p>	<p>-</p>	<p>15</p>	<p>-</p>	<p>CS</p>	<p>-</p>	<p>A</p>	<p>-</p>	<p>A</p>	<p>-</p>	<p>1</p>	<p>-</p>	<p>R</p>	<p>-</p>	<p>HT05</p>	<p>-</p>	<p>UX</p>	<p>-</p>	<p>1</p>	<p>-</p>	<p>03A</p>	<p>-</p>	<p>A</p>	<p>-</p>	<p>0</p>	<p>(Example part number)</p>

Model
PFHT meter body system (1P,1R)
PFHT meter body system (2P,1R)
PFHT meter body system (1P,2R)
PFHT meter body system (1P,3R)
PFHT meter body system (1P,4R)
PFHT meter body system (2P,4R)

Meter body size
3in (80mm)
4in (100mm)
6in (150mm)
8in (200mm)
10in (250mm)
12in (300mm)
14in (350mm)
16in (400mm)
Special size

Meter body flange
150# Flange
300# Flange
600# Flange
Special flange

Meter body material
Carbon steel
Stainless steel
9Cr-1Mo
Special material

Meter body paint
No paint
Standard gray epoxy paint
Gray high temp Tmax=400°C
Custom paint

Meter body design
ASME B31.3 and NACE MR0103
PED compliant and NACE MR0103

Meter body NDE
NDE: MPI, X-ray, and hydro
NDE: MPI, X-ray, hydro and PMI
NDE: LPI, X-ray, and hydro
NDE: LPI, X-ray, hydro and PMI

Transducer cable (select separately)
Remote cable (select separately)

Transducers and buffers
0.5 MHz HT (-200 to 600°C)
0.5 MHz NT (-200 to 315°C)
0.2 MHz HT (-200 to 600°C)
0.2 MHz NT (-200 to 315°C)

Junction boxes
Explosion proof AL enclosure
Explosion proof 316 SS enclosure

Certification
Div 1, Class 1, Group B,C,D
ATEX II 2 G hazardous location
IECEx hazardous locations

Certifications
3IN,2-pt cal
4IN,2-pt cal
6IN,2-pt cal
8IN,2-pt cal
10IN,2-pt cal
12IN,2-pt cal
14IN,2-pt cal
16IN,2-pt cal
3IN,2-pt cal (ISO17025)
4IN,2-pt cal (ISO17025)
6IN,2-pt cal (ISO17025)
8IN,2-pt cal (ISO17025)
10IN,2-pt cal (ISO17025)
12IN,2-pt cal (ISO17025)
14IN,2-pt cal (ISO17025)
16IN,2-pt cal (ISO17025)
Special calibration

System transmitters (select separately)
XMT1000 (1) (select separately)
XMT1000 (2) (select separately)
XMT1000 (3) (select separately)
XMT1000 (4) (select separately)
XMT1000 SIL (1) (select separately)
XMT1000 SIL (2) (select separately)
XMT1000 SIL (3) (select separately)
XMT1000 SIL (4) (select separately)
XMT1000 (1), XMT1000 SIL (1) (select separately)
XMT1000 (1), XMT1000 SIL (2) (select separately)
XMT1000 (1), XMT1000 SIL (3) (select separately)
Special configuration

Special
None
Special

IPIR design

Configuration	Nominal pipe size (in)	FTF length in (mm)	Width in (mm)	Height (local) in (mm)	Height (remote) in (mm)	Mass lbs (kgs)
ZIH	3	30 (762)	40 (1016)	27 (686)	20 (508)	143 (65)
	4	30 (762)	41 (1042)	28 (712)	22 (559)	191 (87)
	6	36 (915)	43 (1093)	31 (788)	25 (635)	250 (113)
	8	36 (915)	45 (1143)	33 (839)	27 (686)	420 (191)
	10	42 (1067)	47 (1194)	36 (915)	30 (762)	615 (279)
	12	42 (1067)	49 (1245)	38 (966)	32 (813)	649 (294)
	14	48 (1220)	51 (1296)	40 (1016)	33 (839)	849 (385)
	16	54 (1372)	53 (1347)	42 (1067)	36 (915)	1133 (514)

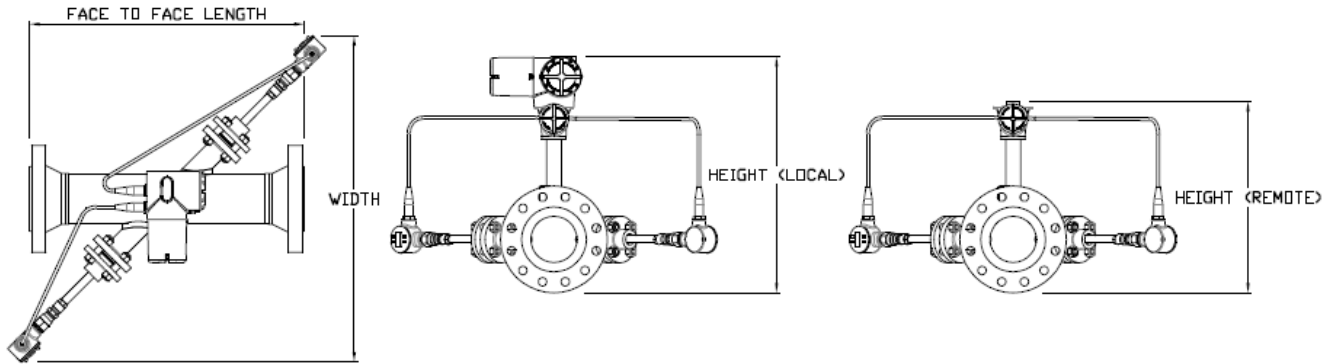

2PIR design

Configuration	Nominal pipe size (in)	FTF length in (mm)	Width in (mm)	Height (local) in (mm)	Height (remote) in (mm)	Mass lbs (kgs)
Z2H	6	42 (1067)	41 (1042)	35 (889)	29 (737)	352 (160)
	8	42 (1067)	43 (1093)	36 (915)	30 (762)	484 (220)
	10	48 (1220)	45 (1143)	38 (966)	32 (813)	676 (307)
	12	48 (1220)	47 (1194)	39 (991)	33 (839)	802 (364)
	14	54 (1372)	48 (1220)	40 (1016)	34 (864)	911 (413)
	16	54 (1372)	49 (1245)	42 (1067)	36 (915)	1194 (542)

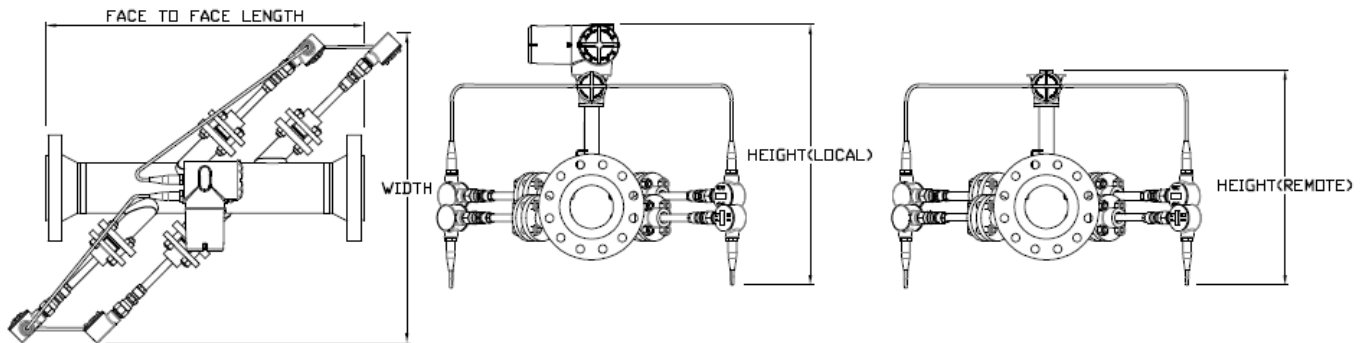

IP2R design

Configuration	Nominal pipe size (in)	FTF length in (mm)	Width in (mm)	Height (local) in (mm)	Height (remote) in (mm)	Mass lbs (kgs)
R2H	3	48 (1220)	40 (1016)	27 (686)	20 (508)	244 (111)
	4	54 (1372)	41 (1042)	28 (712)	22 (559)	301 (137)
	6	66 (1677)	43 (1093)	31 (788)	25 (635)	449 (204)

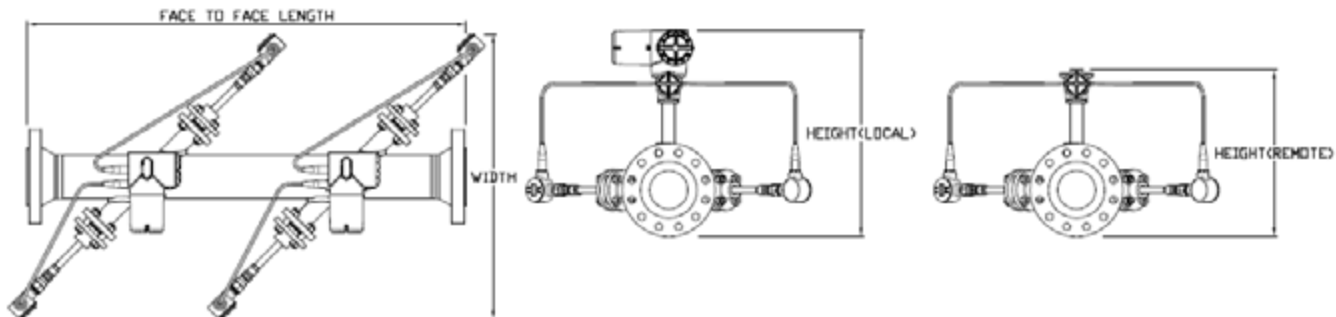

R3H or R4H (redundant three or four path) designs are available upon request.

Panametrics, a Baker Hughes Business, provides solutions in the toughest applications and environments for moisture, oxygen, liquid and gas flow measurement. Experts in flare management, Panametrics technology also reduces flare emissions and optimizes performance.

With a reach that extends across the globe, Panametrics' critical measurement solutions and flare emissions management are enabling customers to drive efficiency and achieve carbon reduction targets across critical industries including: Oil & Gas; Energy; Healthcare; Water and Wastewater; Chemical Processing; Food & Beverage and many others.

Join the conversation and follow us on LinkedIn
[linkedin.com/company/panametricscompany](https://www.linkedin.com/company/panametricscompany)

