



Sentinel LCT

Panametrics ultrasonic flowmeter for liquid custody transfer measurement

Custody transfer flow measurement from panametrics

Panametrics introduces Sentinel LCT, a new addition to our series of advanced ultrasonic flowmeters. Sentinel LCT demonstrates new levels of performance and accuracy, reacts to changes in flow rate with incredible speed and is based on proven technology. Sentinel LCT is designed specifically for the custody transfer measurement of crude oil and other liquid refined products and requirements. Please contact Panametrics for details.

It's all about reliability

The design philosophy behind Sentinel LCT was simple; build a flowmeter that combined absolute reliability with the highest accuracy. Using ultrasonic technology was the first choice; with no moving parts the meter will not suffer from any mechanical wear or tear. Using a fully welded construction without any gaskets or threaded connections was another choice; there is simply nothing in the meter's geometry that can change to allow the meter to drift.

Robust Path Configuration™

Before Sentinel LCT was ever tested on a calibration loop, the meter was already extensively tested in the virtual world. Computational Fluid Dynamics (CFD) was used to simulate different path configurations under different flow scenarios. CFD allowed us to test different ultrasonic path configurations under a number of different flow scenarios, from laminar flows that are typically seen in very heavy crudes to highly turbulent flows that are seen in gasoline and LPG applications. Only after CFD simulation provided the optimal path configuration, was the Sentinel LCT tested in a calibration loop to prove the CFD results. Testing on different viscosity oil products proved the CFD analysis to be right. Sentinel LCT easily met the targeted 0.15% accuracy.

A true multi-viscosity flowmeter

Starting with a meter that already has minimal sensitivity to viscosity changes, Sentinel LCT uses a number of proprietary algorithms to even further reduce the viscosity effects. As a result, Sentinel LCT is a true multi-viscosity meter, meaning no prover run or change of settings is required when the viscosity changes. The meter stays within 0.15% accuracy over the whole range between minimum and maximum viscosity, using only one calibration curve.

Maintenance free

Not only does the meter lack any mechanical parts that require maintenance, the meter also does not require any filter or strainers. Inspecting and replacing clogged filters is not required, simply because they are not there. Theoretically the meter does not even require any recalibrations; however, local legal requirements might require differently.

No pressure drop

Due to the unique ultrasonic path configuration, the flowmeter design does not have any diameter reductions. This means the design is completely full bore in the same diameter as your pipeline. As a result the pressure drop over the meter is simply equal to a section of pipe with the same length.

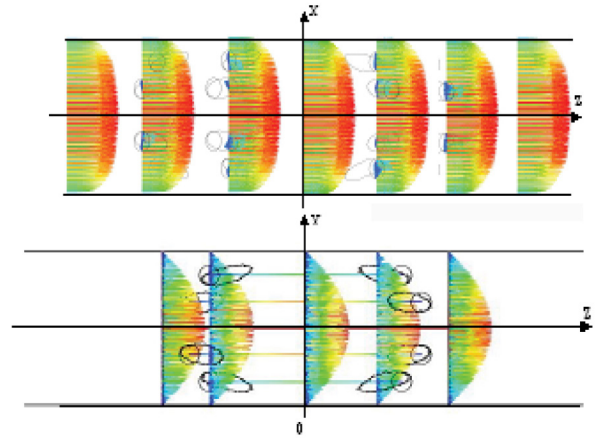

CFD analysis of the ultrasonic port effects. The top graph shows the effect under turbulent flow, the bottom graph under laminar flow conditions. Also note the different flow profiles under these conditions.

Benefits

- Extremely reliable and highly accurate flowmeter, designed specifically for custody transfer measurements.
- Viscosity independent. Measurement accuracy will not be affected by a change in viscosity or density.
- Fully welded construction with no moving parts. No filters or strainers required.
- Full bore design, zero pressure drop.
- Robust Path Configuration™ through extensive use of CFD (Computational Fluid Dynamics).
- Optionally built-in flow computer for API MPMS 11.1 corrections for temperature and pressure.

Applications

- Liquid custody transfer measurement
- Allocation measurement
- Pipeline leak detection
- Crude oil and refined products
- High temperature flow
- Cryogenic flow
- Any liquid flow needing high accuracy and precision

24" Sentinel LCT combined performance results: NMI witnessed results for OIML R117-1 certification at SPSE

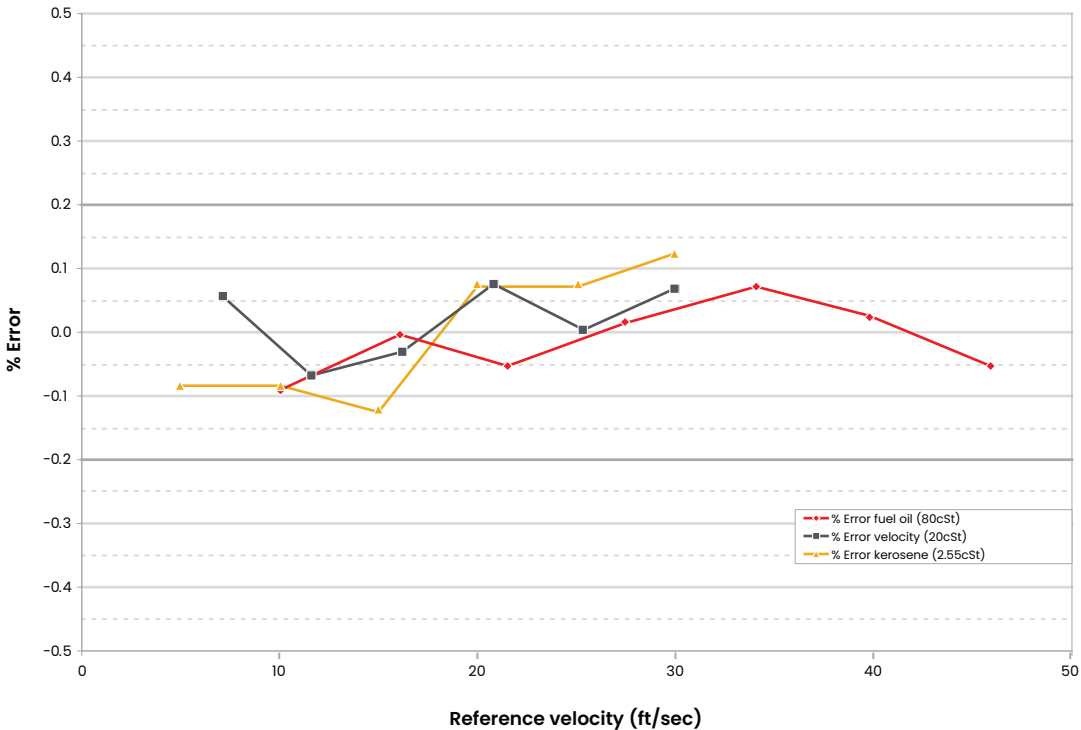
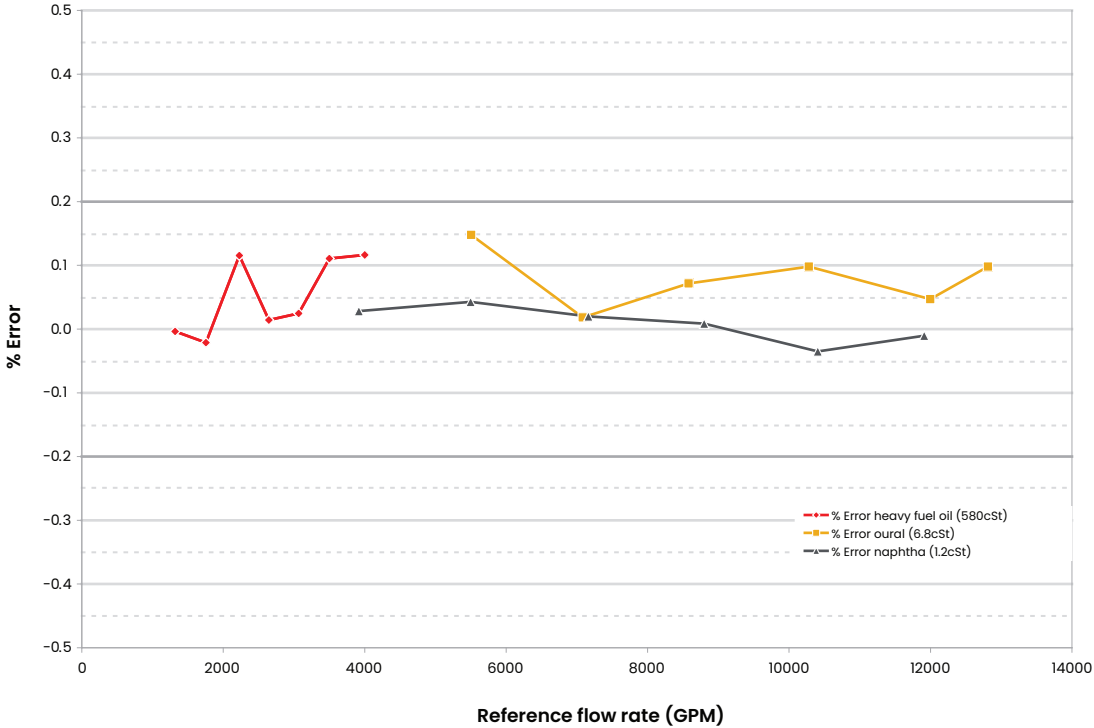

Active Temperature Compensation™

Ultrasonic flowmeters use transit time to determine the liquid or gas flow in a pipeline. Measured transit time consists not only of the time the ultrasonic signal spends in a fluid, but also of a portion of “dead time,” being the time that the electrical signal is converted into an acoustical signal and the time the acoustic signal travels inside the transducer. To allow for the utmost accuracy, Sentinel LCT uses pulse echo to actively measure the dead time. By sending a pulse and measuring its reflection, the dead time is measured in real time rather than using a preset value. As a result of this Panametrics invention, Sentinel LCT maintains custody transfer accuracy as process temperature conditions dynamically change.

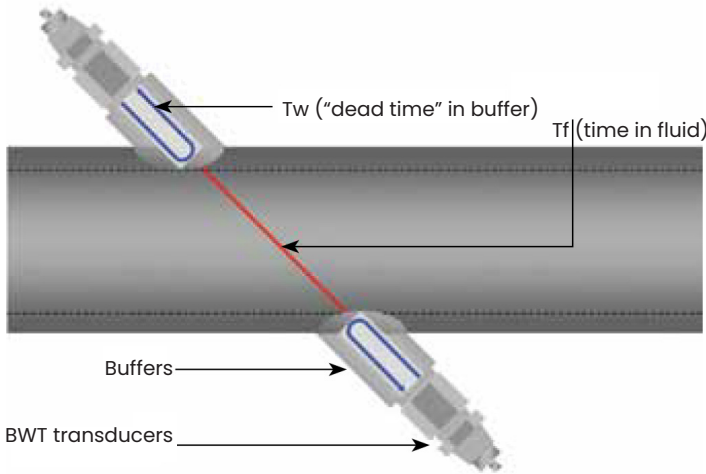

Built-in flow computer

Optionally the Sentinel SEN898 electronics have a built-in flow computer that allows for temperature, pressure and density corrections according to API MPMS 11.1. By connecting an external pressure, temperature and, if required, density measurement, all API corrections are done inside the SEN898 electronics, reducing the need for an external flow computer.

One-time calibration

The Sentinel LCT requires a single calibration event (multi-viscosity or water, depending on the application) to work over the entire user flow range without the need for frequent calibration checks or prover runs. There is no need for recalibration when replacing sensors or electronics. NMI tested and certified that the Sentinel LCT maintains custody transfer accuracy and calibration integrity after component exchanges!



Advanced electronics

Sentinel LCT has advanced digital signal processors that pack significant power in a simple package. Several output options are standard. The electronics can be mounted on the flowcell section or up to 300 feet away. Cable connections can easily be accessed, even when the meter has been mounted to a wall. HART is standard on all meters. Local diagnostics can be done via magnetic contacts through the glass, or by using the USB connection and our PanaView™ software.

PanaView™ for diagnostics

PanaView software facilitates communication between a PC and the Sentinel LCT flowmeter. This software monitors the Sentinel flowmeter to provide a secure and comprehensive check on the meter configuration with a full audit trail. It also allows live flow readings and tracking of flow diagnostics.

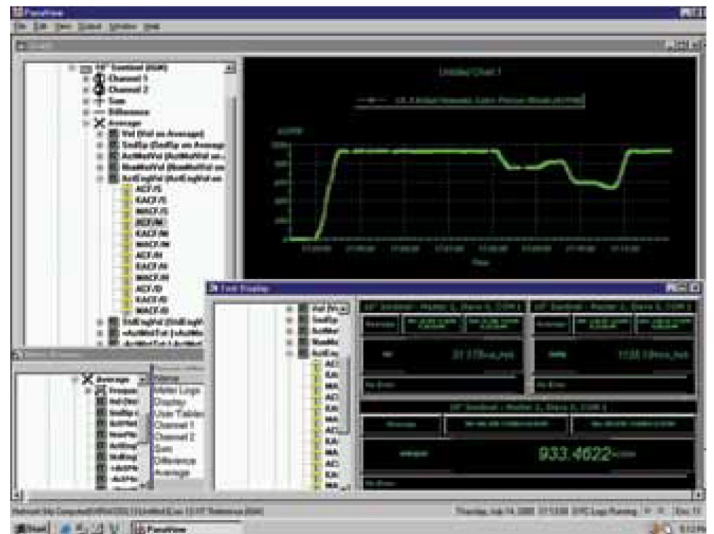

Dimensions and weights

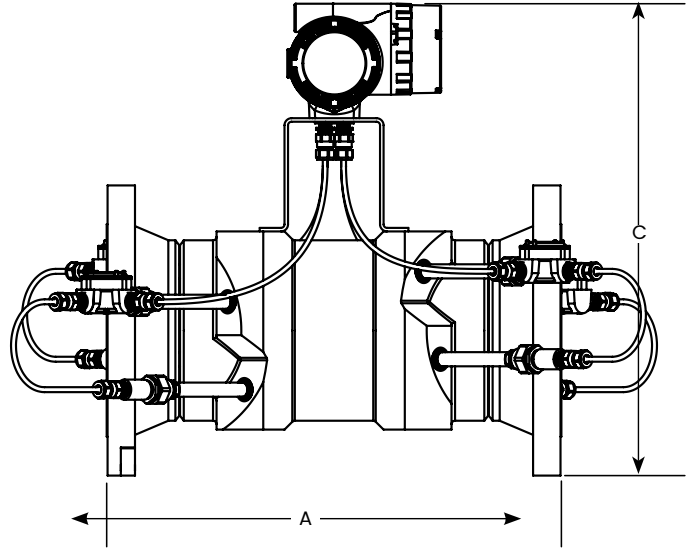
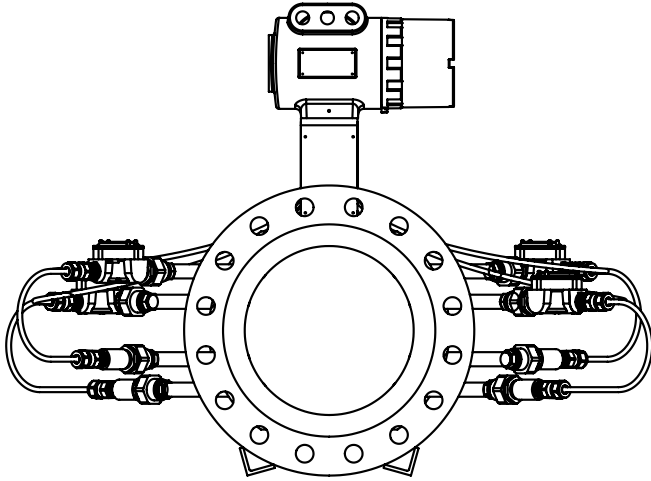

Dimensions and weights in English units

Diameter	Flange	A (in)	C (in)	Weight (lb)
4	150#	20	23.49	149
	300#	20	23.99	176
	600\$	20	24.36	200
6	150#	22	25.76	209
	300#	24	26.51	265
	600\$	26	27.26	338
8	150#	26	27.59	268
	300#	28	28.34	343
	600\$	30	29.09	452
10	150#	28	29.84	367
	300#	30	30.59	487
	600\$	32	31.84	739
12	150#	30	32.59	478
	300#	32	33.34	681
	600\$	36	34.09	957
14	150#	36	34.09	790
	300#	38	35.09	1079
	600\$	40	35.46	1339
16	150#	38	36.84	989
	300#	40	37.84	1348
	600\$	42	38.59	1770
18	150#	38	37.84	1056
	300#	40	39.34	1527
	600\$	44	39.96	2076
20	150#	46	41.25	1424
	300#	48	42.75	2120
	600\$	50	43.50	2819
24	150#	48	44.59	1990
	300#	50	49.59	2947
	600#	52	47.09	3946

Dimensions and weights in metric units

Diameter	Flange	A (mm)	C (mm)	Weight (kg)
4	150#	508	597	68
	300#	508	609	80
	600\$	508	619	91
6	150#	559	654	95
	300#	610	673	120
	600\$	660	692	153
8	150#	660	701	122
	300#	711	720	156
	600\$	762	739	205
10	150#	711	758	166
	300#	762	777	221
	600\$	813	809	335
12	150#	762	828	217
	300#	813	847	309
	600\$	914	866	434
14	150#	914	866	358
	300#	965	891	489
	600\$	1016	901	607
16	150#	965	936	449
	300#	1016	961	611
	600\$	1067	980	803
18	150#	965	961	479
	300#	1016	999	693
	600\$	1118	1015	942
20	150#	1168	1048	646
	300#	1219	1086	962
	600\$	1270	1105	1280
24	150#	1219	1133	903
	300#	1270	1183	1337
	600#	1321	1196	1790

Dimensions and weights: single plane

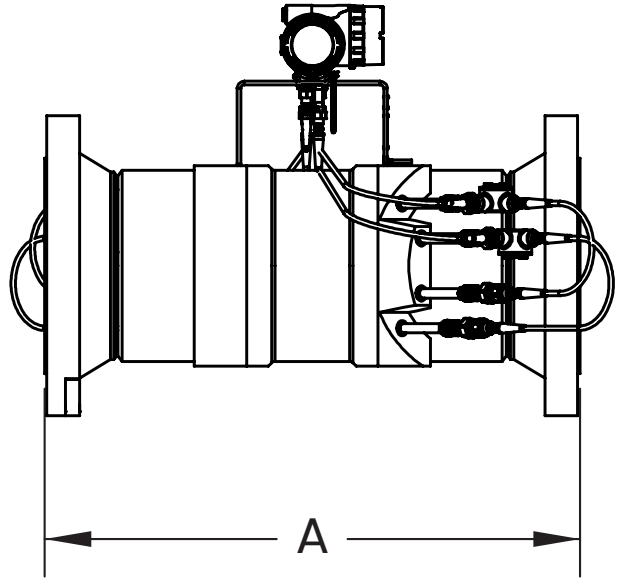
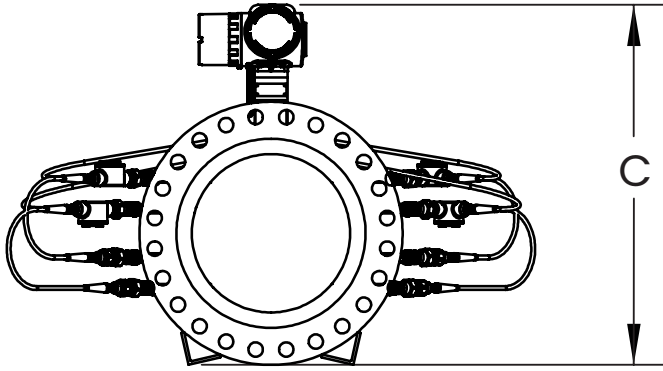

Weights are based on carbon steel spool and stainless steel enclosure.

Diameter, Inches	Flange	A		B		Weight	
		in	mm	in	mm	lb	mm
12	150#	30	762	33.59	853	476	216
	300#	32	813	34.34	872	685	310
	600\$	36	914	35.09	891	1010	458
14	150#	36	914	34.84	885	740	336
	300#	38	965	35.84	910	1080	490
	600\$	40	1016	36.21	920	1217	552
16	150#	38	965	37.64	948	843	382
	300#	40	1016	38.34	974	1257	570
	600\$	42	1067	39.09	993	1680	762
18	150#	38	965	38.84	986	843	382
	300#	40	1016	40.34	1025	1572	713
	600\$	44	1118	40.96	1040	2116	960
20	150#	46	1168	41.34	1050	1292	586
	300#	48	1219	42.84	1088	1588	720
	600\$	50	1270	43.59	1107	1899	861
24	150#	48	1219	35.59	1158	1908	866
	300#	50	1270	47.59	1207	2932	1330
	600\$	52	1321	48.09	1221	3476	1577
28	150#	56	1422	49.29	1252	876	398
	300#	56	1422	51.41	1306	1858	843
30	150#	60	1524	51.41	1306	1858	843
	300#	60	1524	53.54	1360	2130	970
32	150#	64	1626	53.92	1369	1300	590
	300#	64	1626	55.67	1414	2400	1090
36	150#	70	1778	58.05	1474	2180	990
	300#	70	1778	60.05	1525	3750	1700

Technical Specifications

Operation and performance

Sentinel LCT has been designed to meet the OIML R117-1, MID MI-005 and API MPMS 5.8 requirements.

Fluid types	Liquid hydrocarbons, crude and refined products, other liquids
Flow measurement	Correlation transit time mode
Accuracy	< ± 0.15% of measured volume for flow rates between 1 and 33 ft/s (0.3 and 10 m/s) (Extended range available upon request)
Uncertainty	< ± 0.027% according to API MPMS 5.8
Zero stability	< 0.003 ft/s (0.0009 m/s)
Viscosity range	0 to 6600 cSt Consult factory for higher viscosity numbers
Reynolds range	> Re 5,000, consult factory for lower Reynolds numbers
Process temperature	<ul style="list-style-type: none"> -40° to +120°C (-40° to +248°F) standard -200° to +120°C (-328° to +248°F) LNG -200° to +600°C (-328° to +1112°F) extended range—consult factory
Ambient temperature	-40° to +60°C (-40° to 140°F) (Up to 85°C for short exposures)
Storage temperature	-40° to +80°C (-40° to +176°F)

Meter body

Path configuration	Four path Robust Path Configuration™
Meter body materials	<ul style="list-style-type: none"> Carbon steel A105/A350LF2 Stainless steel A182, Gr 304/304L Stainless steel A182, Gr 316/316L Others on request.
Pipe sizes	4 in (100 mm) to 36 in (900 mm) Others on request.
Flange ratings	<ul style="list-style-type: none"> 150 # 300 # 600 # Others on request.

Pipe schedules	<ul style="list-style-type: none"> 40S STD 80S XS Others on request.
-----------------------	---

PED compliance	PED Cat III, module H
-----------------------	-----------------------

Installation requirement	Meter must be installed with 20D straight piping upstream and 5D straight piping downstream. Inlet and outlet piping shall match the meter ID within 1%. In case 20D inlet cannot be mounted, a 10D inlet with CPA plate flow conditioner is recommended. Pressure, temperature and density connections must be located in the downstream piping. The 20D upstream piping (or 10D with flow conditioner) must be free of items that could disturb the flow profile.
---------------------------------	---

Electronics

Electronics enclosure material	<ul style="list-style-type: none"> Epoxy coated aluminium Stainless steel A351, Gr 316/316L (optional)
Dimension	<ul style="list-style-type: none"> Weight: 25 lb (11.33 kg) (45 lb for SS option) Size (l x h x d): 13 x 11 x 9 in (33 x 28 x 23 cm)
Environmental protection	IP66
Power supply	<ul style="list-style-type: none"> 100 to 240 VAC 12 to 32 VDC
Power consumption	7 watt
Display	High contrast 128 x 64 pixel graphical display with LED illumination.
Outputs	<ul style="list-style-type: none"> Two frequency/pulse outputs optically isolated from DC Two alarm relays One 4/20 mA output with HART
Inputs	Two 4/20 mA and one 100 ohm RTD input for density, pressure and temperature input (option). Three 4/20 mA inputs for density, pressure and temperature input (option).
Digital interfaces	<ul style="list-style-type: none"> HART over 4/20 mA output PanaLink over RS232/485/USB Modbus over RS232/485 (option)

Typical certified flow ranges – extended velocity ranges available

Nominal Diameter		0.3 m/s	10 m/s	0.3 m/s	10 m/s	0.3 m/s	10 m/s
		1.0 ft/s	33 ft/s	1.0 ft/s	33 ft/s	1.0 ft/s	33 ft/s
in	mm	(m ³ /h)	(m ³ /h)	(GPM)	(GPM)	(BBL/h)	(BBL/h)
4	100	10	340	44	1500	63	2100
6	150	20	940	86	940	123	5900
8	200	35	1500	152	6600	217	9440
10	250	54	2050	238	9030	340	12900
12	300	77	2550	340	11200	480	16000
14	350	110	3500	470	15400	670	22000
16	400	140	4550	610	20000	870	28600
18	450	170	5750	770	25300	1100	36200
20	500	220	7100	950	31300	1350	44700
24	600	300	9900	1320	43600	1890	62300
26	650	370	12100	1600	53200	2300	76000
28	700	430	14000	1900	62000	2670	88000
30	750	490	16100	2150	71000	3100	101000
34	850	630	20700	2800	91000	3950	130000
36	900	700	23200	3100	102000	4400	145800

Typical flow rates for 0.3 m (1 ft.) per second and 10 m (33 ft.) per second are listed above. The Sentinel LCT is a full bore meter and the flow range is a function of the pipe and not the meter itself.

Flow computer functionality Integrated flow computer with full P and T volume corrections according to API 11.1

Hazardous area certifications

- USA/Canada: Class 1, Div 1, Groups B, C, & D
- Europe: ATEX II 2 G Ex de IIC (Ex d IIC as option)
- IEC Ex: Ex de IIC (Ex d IIC as option)

CE compliance 2004/108/EC EMC Directive
2006/95/EC LVD

Custody transfer approvals

USA Compliant with API MPMS 5.8

Europe WELMEC Guide 8.8 under the MID.

Rest of world OIML R117-1 by NMI (TC7595 Evaluation Cert). Local country specific type approvals available. The custody transfer approvals are valid for the flowmeter only. These approvals are not applicable for the built-in flow computer.